



Please Read Instructions Carefully Before Installation!

■ Safety



- This product is not intended to be used for Life or Safety applications.
- This product is not intended for use in any hazardous or classified locations.



- Disconnect and lock out all power sources before installation as severe injury or death may result from electrical shock due to contact with high voltage wires.

■ Inst

Make s
familiar
switch



Warni

The A/
moun
1" (3 cr

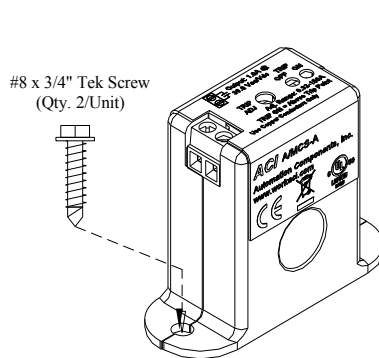

Figure 1: A/MCS-A

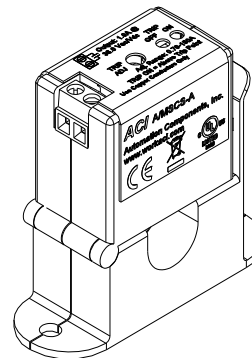

Figure 2: A/MSCS-A

For applications in which the normal operating current is below the 0.32Amps (A/MCS-A) or 0.70Amps (A/MSCS-A) trip point (See Figure 3 below), the conductor being monitored may be looped through the sensor 6 times giving you a total operating current of 6X the original current. **Example:** A small fan operating at 0.2A should be wrapped through the sensor 7 times to give you a total operating current of 1.4Amps flowing through the A/MCS-A or A/MSCS-A.

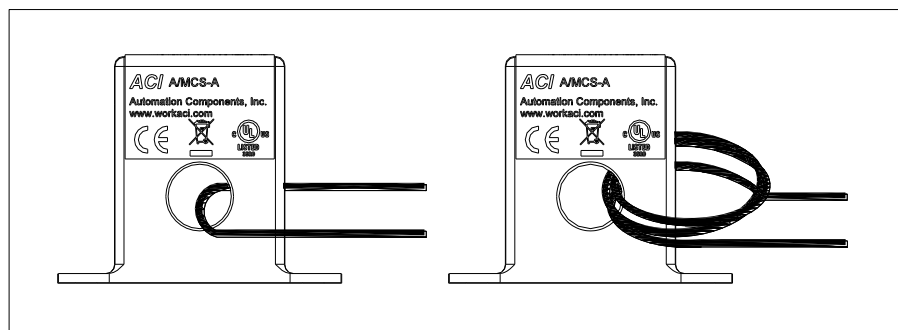

Figure 3: Wires Through Sensors

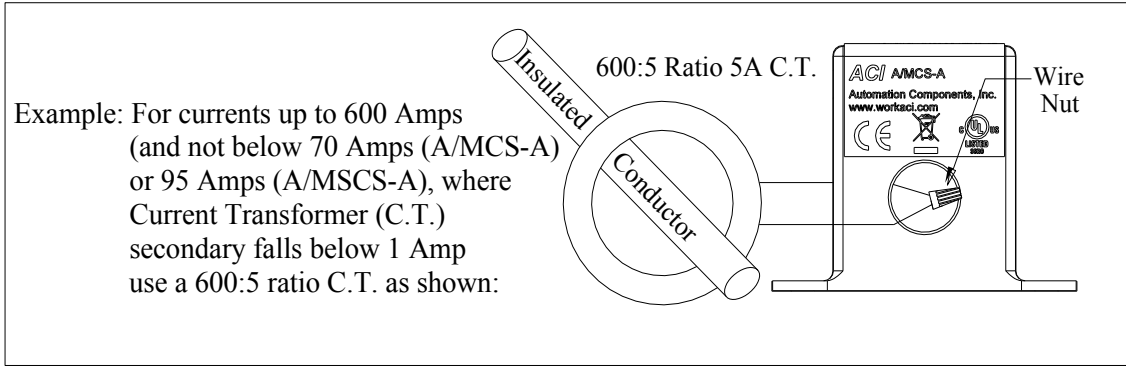

Figure 4: Current Transformer

■ **Wiring**

ACI recommends the use of a two conductor 16 to 22 AWG shielded cable or twisted pair **copper wire only** for all current switch applications. A maximum wire length of less than 30 meters (98.4 feet) should be used between the A/MCS-A and A/MSCS-A current switches and the Building Management System or controller. **Note: When using a shielded cable, be sure to connect only (1) end of the shield to ground at the controller. Connecting both ends of the shield to ground may cause a ground loop.** When removing the shield from the sensor end, make sure to properly trim the shield so as to prevent any chance of shorting. The current switch output terminals represent a solid-state switch for controlling both AC and DC loads and is not polarity sensitive. The recommended torque to be used on the terminal block connections is 0.67 Nm or 5.93 in-lbs... The aperture (hole) size of the current switch is 0.53” (1.35 cm) and will accept a 1 AWG maximum wire diameter.

ACI Model #	Adjustable Trip Point	Output Switch Rating	Max. Sensing Current Voltage	Max. Continuous Current	Max. Current for 6 seconds	Max. Current for 1 second
A/MCS-A	0.32 - 150 Amps	1.00 Amp @ 36 VAC/VDC	600 VAC	158 Amps	240 Amps	600 Amps
A/MSCS-A	0.70 - 150 Amps	1.00 Amp @ 36 VAC/VDC	600 VAC	158 Amps	240 Amps	600 Amps

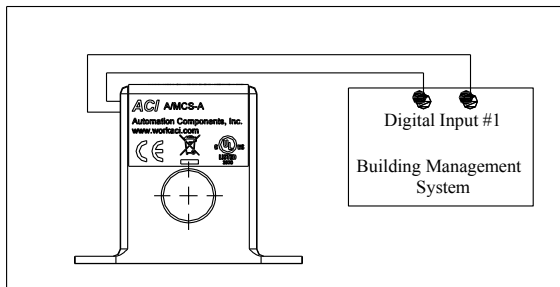

Figure 5: Digital Circuit

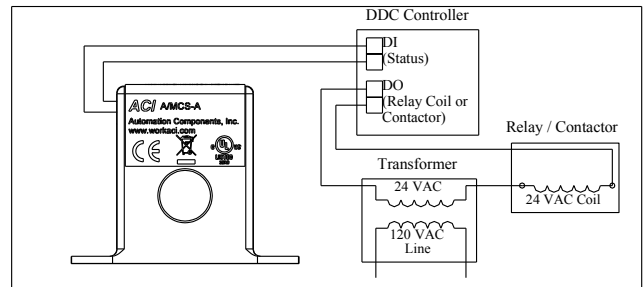

Figure 6: Analog Circuit

■ Calibration of Adjustable Trip Point

The adjustable current switch has an operating range of 0-150 Amps. **Do not exceed!** The adjustable current switch comes with its fifteen-turn adjustment potentiometer set to the 100 Amp trip point position. The adjustable current switch can be used to monitor Under Load, Normal Load, and Over Load conditions, depending on how it's set. The procedure below is for the Normal load condition for part numbers A/MCS-A & A/MSCS-A.

■ Normal Loads

With current flowing through the aperture of the A/MCS-A and A/MSCS-A current switches, first verify that the Blue LED is on. If the Blue LED is on, now slowly adjust the potentiometer clockwise until the Red LED just turns on and stop immediately. This will set the trip point at your normal operating load current. If the RED LED is on after initial power up, this means that you will need to slowly adjust the potentiometer counter-clockwise until the Blue LED turns on and then slowly adjust the potentiometer clockwise until the Red LED just turns on and stop immediately. The adjustable current switch is now tripped. Now verify the output with an Ohmmeter to verify that the contacts of the switch are approximately 0.200 Ohms. The adjustable current switch Hysteresis (Dead Band) is typically 10% of the trip point.

■ Troubleshooting

Problem	Solution
Red LED is on but the current switch didn't activate	Disconnect the wires from the current switch output. Measure the resistance across the contacts with an Ohmmeter. See Figure 7 below for resistance readings for a good unit.
Red LED didn't turn on and the current switch didn't activate	Verify that the conductor you are monitoring is above the adjustable trip point. If the sensor is monitoring less than the adjustable trip point See Figure 3 on Page 1.
Sensor doesn't switch at all, regardless of current level.	Adjustment potentiometer is probably set to its maximum or minimum position. Turn the Pot counter-clockwise all the way and verify if the LED switches from Red to Blue.

ACI Model #	Resistance if switch open	Resistance if switch closed
A/MCS-A	Greater than 1 Meg ohms	Approximately 0.2 ohms
A/MSCS-A	Greater than 1 Meg ohms	Approximately 0.2 ohms

Figure 7

■ WEEE Directive

At the end of their useful life the packaging and product should be disposed of via a suitable recycling centre. Do not dispose of with household waste. Do not burn.

